



Heavy Duty Handset - Hearing Loop & Magnetic Hanger

Product Code: H-H-H-S-HL



- 1 Armoured Cable**
The audio cable is protected by a 1.35m stainless steel armoured conduit cable. With a heavy duty strain relief offering further protection.
 - 2 Magnetic Hanger**
Securely store the handset when not in use with the impact resistant magnetic base. Easily fit to any flat surface with provided screws.
 - 3 T-Coil Technology**
The in-built T-coil system paired with 16Ω speaker elements provide high clarity audio compatible with hearing aids,
 - 4 3.5mm Jack**
Simply connect to your audio playback device via the 3.5mm jack.
 - 5 90° Swivel Knuckle**
The supplied swivel knuckle is used to fix the handset in place, offering a secure anchor point and preventing cable fracture.
- ✓ Material**
Constructed from high grade impact resistant plastic.
 - ✓ Optional Printed Label**
Customise your handset with optional printed labels.



Technical Information

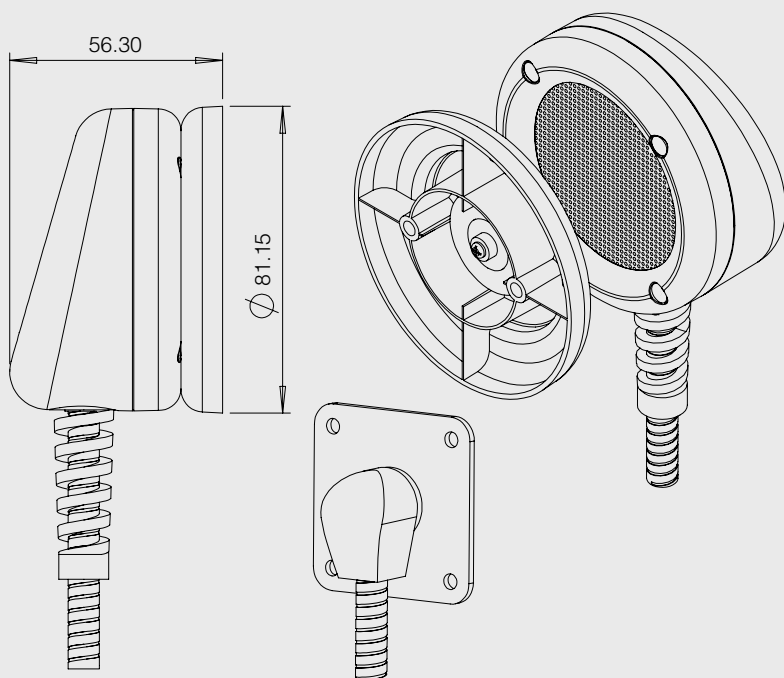

Package Weight	503g
Package Dimensions	180 x 160 x 80mm
Nominal Impedance	16Ω
Frequency Range	0Hz - 20KHz
Sound Pressure Level	123 dB
Input Power (W)	Rated: 30mW - Max: 50mW
Input Power (V)	Rated: 1.7V - Max: 2.25V
Colour	Black or Silver
Armoured Cable Length	1350mm
3.5mm Cable Length (from Knuckle)	650mm (+/- 10mm)
Screw Sizes	Wood Screws (Driver bit No.2, 30mm), Machine Screws (M4, 30mm)
Operating Temperature	-25°C to 60°C
Hearing Aid Compatible	ADA/DDA
Included	1 x Heavy Duty Handset, 1 x Magnetic Hanger, 1 x Knuckle Mounting Plate, 2 x Wood Screws & 2 x Machine Screws (for Hanger)

Custom Branding Labels



Related Products

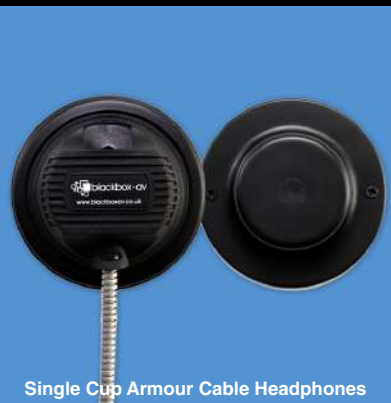

Single Cup Armour Cable Headphones



VideoClip-HD8



MKII Armour Cable Headphones



SoundClip-2