



# **15" POS Android Tablet**

## **Manual**

V1.4

## Contents

Safety Guide .....	3
Your 15" POS Android Tablet.....	4
Setting Up .....	5
Overview.....	5
Android Navigation Buttons .....	6
WiFi Connection .....	7
Remote Control .....	8
Fitting Options .....	9
Technical Information.....	12
Technical Drawings.....	13

## Safety Guide

Please observe the following when installing this device.

### Warning

- This product is not designed to be resistant to moisture or excessive dirt/dust. When deciding on a suitable installation point ensure there is reasonable protection from environmental damage.
- If there is damage to the power supply in any way, arrange for a replacement unit by contacting blackbox-av. They may require you to send the defective power unit back so in this case do not dispose of the power supply unless prompted to do so. If you wish to source your own power supply a CE or FC certified double insulated and regulated supply is required. The Power supply has an output rating of 12vDC at 2A, 24W. Using a power supply with a higher voltage will irreparably damage the display unit.
- Please keep the device away from excess temperature (40°C above), cold (-5°C below) or wet locations. Do not place the unit in direct sunlight for prolonged periods as this may cause the product to overheat.
- For disposal of old electrical equipment please follow the guidelines associated with your country/territory or ship the unit back to blackbox-av and we will dispose/recycle the unit. The symbol on the left indicates that this product shall not be treated as household waste. Instead it shall be handed to applicable collection points for the recycling of electronic equipment. If you dispose of this unit correctly you will be helping prevent future harm to the environment which is caused by poor waste management of this type of equipment.

If the screen has been damaged take extra care to prevent the LCD liquid from leaking out of the unit and wrap in a strong plastic bag with no holes.

### Precautions of Use

- Whilst the unit is connected to a mains outlet and the power is switched on it is providing energy for operating the device. If the unit is not being used for long periods of time it is recommended to turn off the power as it will prolong the life of its electronic circuitry.
- Arrange cables so that they do not become a trip hazard for people/pets.
- Do not place heavy or sharp objects on the LCD panel.

## Your 15" POS Android Tablet

### In the box

1. 15" POS Android Tablet
2. 1 x Remote Control
3. Screw-in Screen Stand
4. Power Cable
5. User Manual
6. Mount (Optional)
7. Security Case



### Android Tablet

The Tablet uses capacitive touch technology with a 15.6" IPS Panel. With a High Definition resolution of 1920 x 1080 high specs and in-built android OS, the tablet is ideal for running android applications.

### Power Input

The tablet is completely powered by mains. The screen will turn on when the power is connected and turns off when power is disconnected.



The power cable (supplied) and audio cables (not supplied) can be secured in place behind the security casing.

## Setting Up

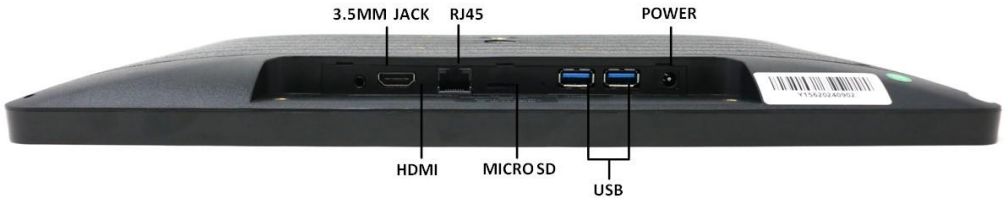

## Overview

### Security Case

Secure inputs behind the supplied security cover. Simply screw on the cover to avoid public interference. See page 9.

### Screw-in Screen Stand

The supplied Screen Stand can be used to prop your Tablet up on a flat surface.

### USB Connections

The Tablet offers 2 USB 3.0 connections.

### HDMI Output

The Tablet comes with a HDMI Output connection, allowing you to display the device's contents onto a second screen.

### Micro SD Card

The Micro SD Card slot supports cards up to 32GB (not supplied).

### 3.5mm Jack

Connect headphones or other output devices via the 3.5mm jack.

### RJ45

If you require wired internet access, simply connect an ethernet cable to the onboard port.

# Android Navigation Buttons

## Enabling / Disabling Navigation Buttons

Note: Ensure Remote is working before enabling this setting.

If you wish to hide the android navigation bar, you will need to follow these steps. This is an important setting to lock users into one application.

### 1. Home Screen

First head to your home screen and select the apps icon at the bottom of the screen.

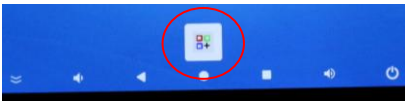

### 2. Settings

Select settings icon.

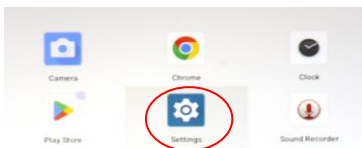

### 3. Display

Scroll down to the Display tab settings.

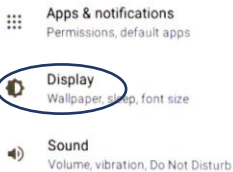

### 4. Advanced

Within the Display tab, scroll down to the Advanced dropdown.

Swipe Up Show NavigationBar  
Enable swipe up to Show NavigationBar



### 5. Find Navigation Bar

Within the Advanced dropdown, scroll down to the "Show NavigationBar"



### 6. Disable the Setting

Press the button on the right side of the page to deactivate the setting.



### 7. Re-Enabling Navigation

'As you can see the navigation is now disabled, to enable follow the same steps but choose to show navigation bar'.

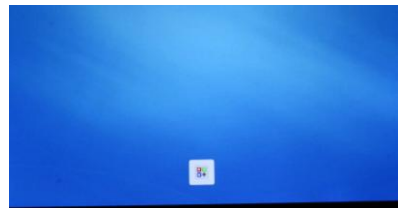

# WiFi Connection

If you wish to connect Tablet to the WiFi, follow the steps below:

## 1. Apps

Select apps icon.



## 2. Settings

Select settings icon.

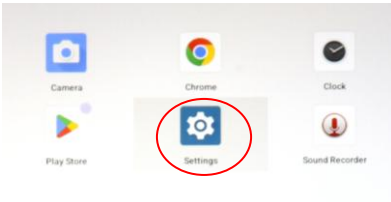

## 3. Network & Internet

Once in the settings, select the Network & Internet option.

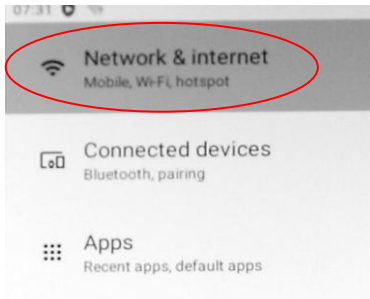

## 4. Internet Networks

Enter the Internet option within this menu.

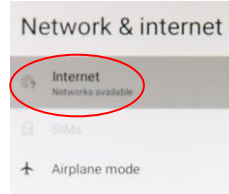

## 5. Turning on WiFi

Turn your WiFi on by selecting the top right button.

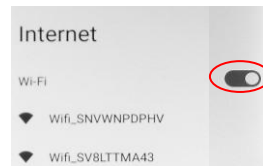

## 6. Connect to WiFi

Select your WiFi and enter the password.

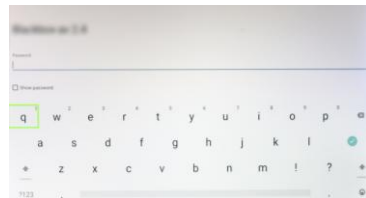

## Remote Control

Point the remote at the IR receiver to the right of the Tablet.



### Sleep Mode

Pressing this button will put the screen into sleep mode to turn on / off you should power the unit up/down via the mains.

### Home Button

Pressing the Home Button will take you to the home screen. This is where your application icons are usually stored.

### Volume

You may adjust the volume level via the remote control, however you can also change this in the settings > sound options. The set volume will be saved and will stay like this even after powering on/off.

### Back Button

Selecting the Back Button will navigate you to the previous screen.



## Fitting Options

### Security Casing

To fit your security case on the rear of the tablet, you first need to make sure the screw-in screen stand has been taken off.

1. Connect the inputs / outputs then thread any wires through the open slots below the casing.
2. Safely slide the case into position above the screw holes, clicking it into place.
3. Next place both thumb screws into the screw holes.
4. Securely fit the screws into place.



## Tilt Mount

If you purchased the Tablet with the Tilt Mount, you will receive the mount as one piece. To fit to the Tablet, follow the steps below:

### 1. Separating the Mount

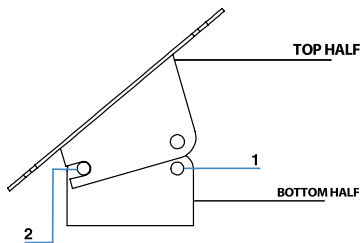

1. Undo and remove both rear screws from the mount.
2. Slightly loosen both front screws (but do not remove) and gently slide out the bottom half of the mount.

### 3. Fitting to the Tablet

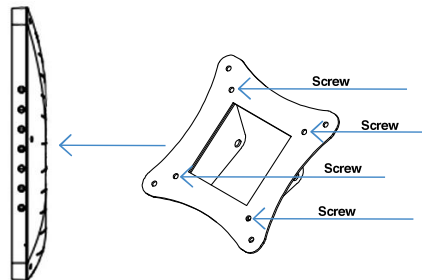

Place 4 screws through the top half of the mount and fit this onto the Tablet.

### 2. Mount to your Surface

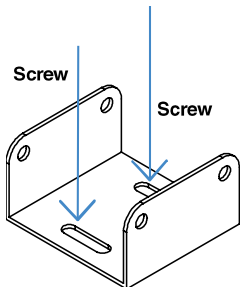

You will now need to fit the bottom half of the mount onto your chosen surface.

### 4. Fixing the Mount

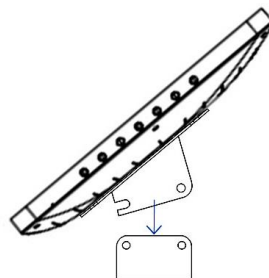

Reverse Step 1 by attaching the top half of the mount to the bottom half and secure back into place.

**Note:** The Tilt Mount is supplied with wall plugs and corresponding screws for fitting to a surface.

## Stand

If you purchased the Tablet with a Stand, you will be provided one with a weighted base.

### 1. Fitting the Tablet

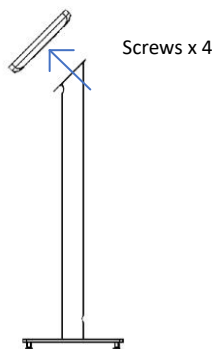

To fix the mount to your Tablet, fit in 4 screws.

### 2. Hiding the Power Cable

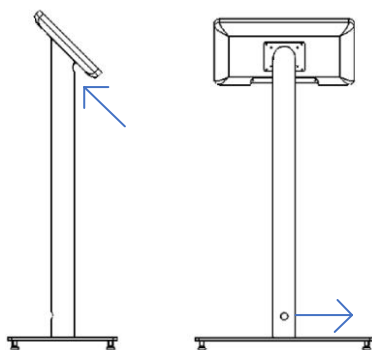

To hide the power cable, thread it through the holes shown in the demonstration above.

## Technical Information

<b>Weight</b>	1.4Kg
<b>Dimensions</b>	392.27 x 29.6 x 241.67mm
<b>Processor</b>	Rockchip Quad Core 64bits Cortex-A55 @ 2.0GHz
<b>Internal Storage</b>	32GB
<b>Memory</b>	RAM 4GB
<b>Operating System</b>	Android 13
<b>Touchscreen</b>	Touchscreen 10-Point Capacitive Touch
<b>Display</b>	15.6" IPS Panel, Display Area: 34.2 x 19.3mm, Aspect Ratio: 16:9
<b>Screen Resolution</b>	1920 x 1080
<b>Brightness and Contrast</b>	300 cdm <sup>2</sup> , 1000:1
<b>Network</b>	WiFi 802.11b/g/n/, RJ45 – Ethernet, Bluetooth 4.0, Supports External USB 3G/4G Dongle
<b>External Connections</b>	2 x USB 3.0, 1 x HDMI Output
<b>Micro SD Card</b>	Card slot supports up to 32GB (Card not supplied)
<b>Audio Output</b>	Standard 3.5mm Stereo Audio Jack
<b>Power Input</b>	1x5.5mm Power DC 12V2A Jack
<b>Camera</b>	2.0MP Front Camera
<b>Operating Temperature</b>	-10°C to ~50°C
<b>Speakers</b>	2x3w Stereo Speakers
<b>Mount</b>	Desktop Stand, Wall Mount, Weighted Stand (7.7Kg Weight), Without
<b>Security</b>	Import Port Supplied with Cover Plate

# Technical Drawings

*Drawings not to scale*

## Tablet

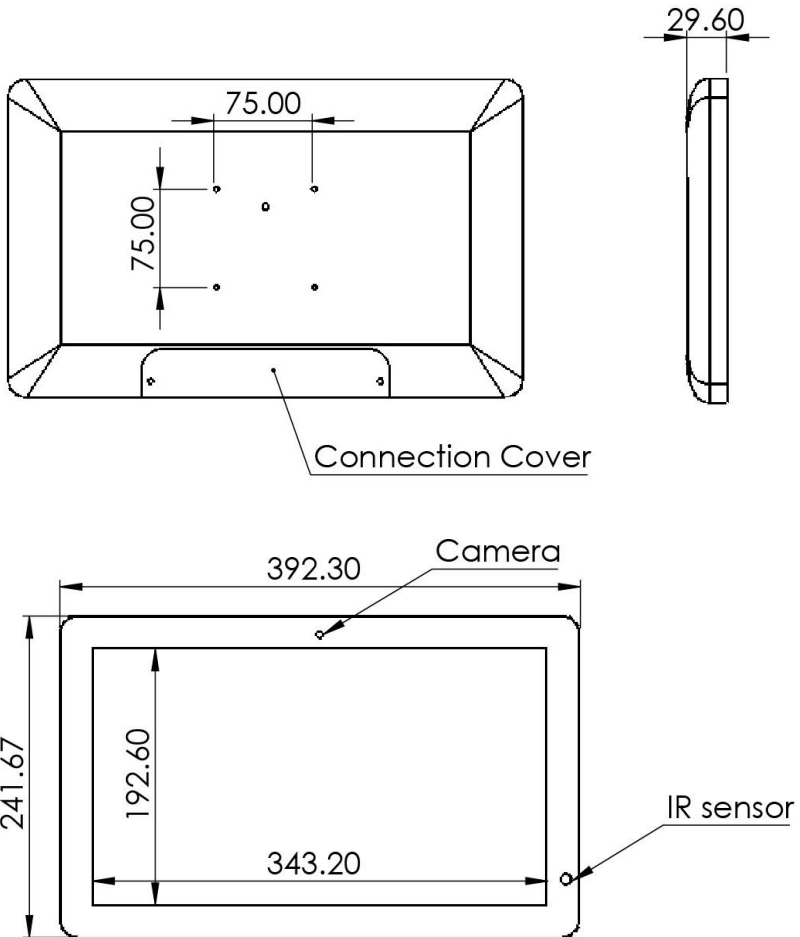

### Desktop Stand

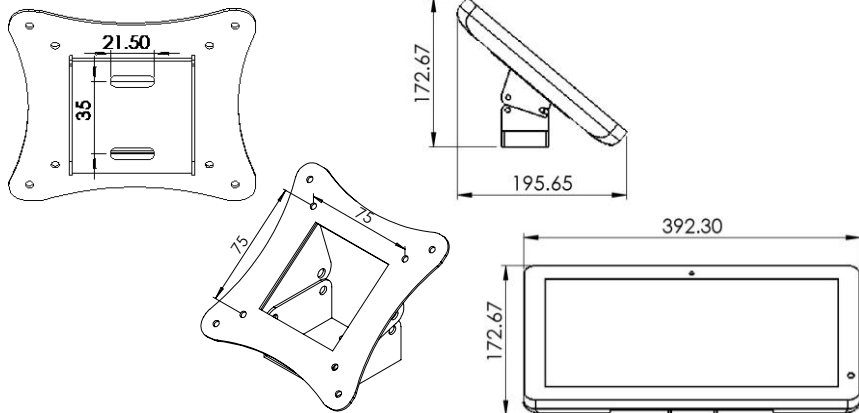

### Weighted Stand

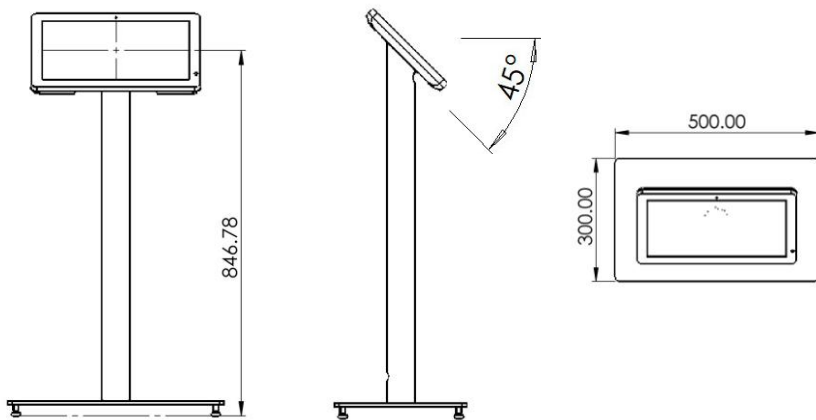

### Wall Mount

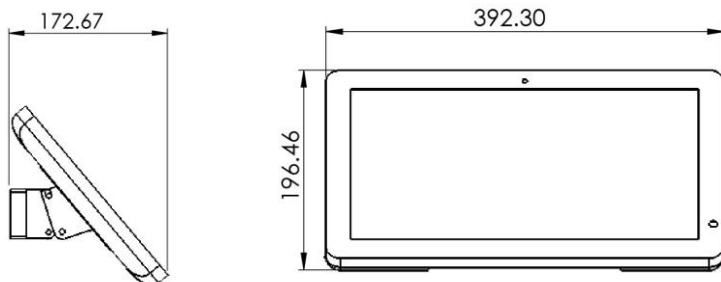

## Notes

