

OPERATIONS GUIDE

Operation of the Solar Post Button could not be simpler...

1. **Movement** in front of the solar post will activate audio track 1. Further movement will activate audio track 2.



ADJUSTING THE VOLUME

There are 4 preset volume levels for the Solar Post which can be selected via the programming port. Once selected, the volume setting is stored and this level will be used for all messages.

1. Activate a message by moving in front of the PIR sensor. Using a dark coloured eg (black insulation tape) cover the PIR hole. This prevents the PIR sensor from activating.
2. Wait a further 10 seconds then fully insert the volume dongle or programmer head into the four clear speaker holes. (See diagram right) Note – If you are using the programming head please ensure that the SD card is removed and power on.
3. Peel back the tape then activate the pir sensor by moving. The unit will play the volume setting message “Volume level 1, volume level 2, volume level 3, volume level 4”. The solar post repeats this message again. The volume level changes for each message to match the volume setting i.e. 1-4.
4. When the desired volume level is heard you should remove the dongle (or programmer head) before the next volume message is played. This sets the volume to the last setting played.
5. The solar post will beep momentarily to indicate that the volume level is stored and the unit is ready for use at the new setting.
6. Remove the tape and then test the volume setting by activating the PIR. Store the dongle or programmer safely for future use.

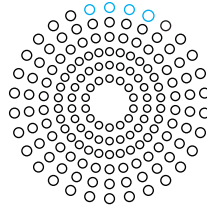

PLAYBACK STATISTICS

The Solar Post is capable of giving playback statistics. This will tell you the total number of times that the unit has played back messages. To get this information please follow the steps below.

1. Activate a message by moving in front of the PIR sensor. Using a dark coloured eg (black insulation tape) cover the PIR hole. This prevents the PIR sensor from activating.
2. Wait a further 10 seconds then fully insert the volume dongle or programmer head into the four clear speaker holes. (See diagram right) Note – If you are using the programming head please ensure that the SD card is removed and power on.
3. Peel back the tape then activate the pir sensor by moving. The unit will play the volume setting message “Volume level 1, volume level 2, volume level 3, volume level 4”. This will then repeat a second time. Leave the volume dongle in.
4. The solar post will next play the playback statistics “message play total zero zero zero zero zero”. This number will be repeated 3 times. You need to remove the volume dongle at this stage unless you want to erase the playback data (back to zero).
5. To erase the playback data simply leave the volume dongle in the unit. You will hear 5 pairs of warning beeps before the information is reset.

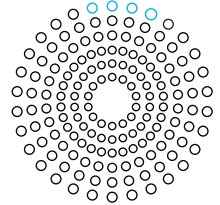

The system will then loop to the start. The message sequence is;
Volume sequence x 2 plays
Message Playback Totals x 3 plays
Erase beeps x 5 plays

6. Remove the dongle from the unit. The volume setting will remain as set before but it is advisable to test the unit by activating the PIR. Store the dongle or programmer safely for future use.

SPECIFICATIONS

Messages

| | |
|---|--|
| Message storage medium: | 32MByte Flash Memory (on board) |
| Maximum number of messages: | 2. Must be 2 files on card no more, no less. |
| Message encoding format: | Windows PCM (*.wav) |
| Message sampling type/rate: | 16 bit mono / 22.05, 16.0, 11.025 KHz |
| Maximum total message length: | >24 minutes@ 11.025KHz |
| Memory Erase Time: | Approx 90 seconds |
| Programming Transfer Rate: | Approx 20seconds/MByte of message |
| Message selection via 2 buttons | |
| Please note: Programmers are not provided as standard with the solar post but are available at additional cost. | |

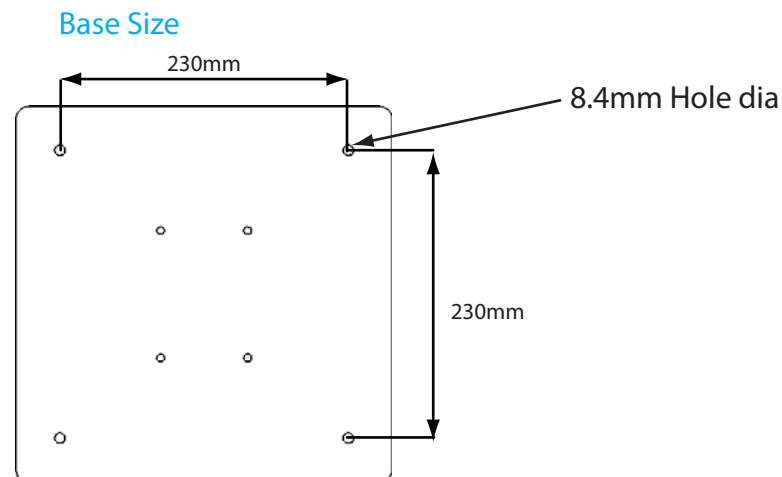

Message Output

| | |
|----------------------------|---------------------------------------|
| Playback sample type/rate: | 12 bit mono / 22.05, 16.0, 11.025 KHz |
| Audio output: | 0.75W into 8ohm speaker |
| Freq. range: | 75Hz-20kHz |

Power

4 built in Solar Panels charging 3 1.2V long life batteries at up to 100mA per hour.
3 x 2200mAh long life batteries.

Weight

Short boxed 6KG (unboxed 5KG)
Tall boxed 9KG (unboxed 8KG)

Size

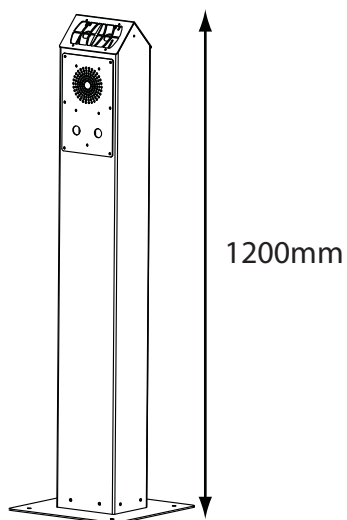
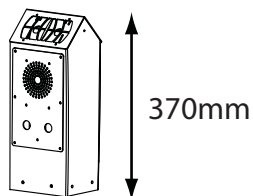

PROGRAMMING GENERAL INFO

The audio files are initially created on a computer. The files are copied to an SD card which is inserted in the hand-held programmer.

The programmer is then connected to the Solar Post and the file transfer process is started. The files are copied to the audio board and stored on the internal on board memory. After completing the transfer, the programmer is removed from the U-Turn and it is ready for use.

The audio file format for the system is Windows PCM file format (i.e. .wav files). The audio must be mono, 16 bit samples at 22.05 KHz sampling (16KHz or 11KHz sampling rates are also allowed). The audio should be normalized to 100% amplitude to ensure best quality when played back on the system.

The SD card MUST be formatted as FAT (not FAT32) with a blank volume name before copying the 'wav' files. This is done by right clicking the SD drive icon from 'My Computer' and selecting FORMAT.

The audio files on the PC hard disc MUST be named '01.wav', '02.wav' etc. up to the last file to be copied. There should be no break in the file name sequence i.e. the name of the last file should be equivalent to the total tracks to be on the card. There can be a maximum of 2 audio files on the SD card.

You then copy each file in turn from the PC hard disc to the SD card root directory. Do not put any other files on the SD card.

Note that copying files to the SD card can take longer than the computer indicates i.e. the computer will show that copying is finished but there is still data to be transferred to the card. Please ensure all files have been copied to the SD card before it is removed. The best way to confirm this is to 'click' the 'Unplug or Eject Hardware' button in the 'System Tray' icons (bottom right of screen), and then select 'STOP xxxxxxxx' where xxxxxxxx represents the SD card drive. If all the data has been transferred then a message will indicate that you can remove the card, if not then wait a while and try stopping the device again. Remember that you should not have 'My Computer' or 'Windows Explorer' accessing the SD card at this time otherwise the computer will assume the card is in use and will not allow it to be removed.

The programmed card should then be inserted to the programmer with the label side up.

PROGRAMMING PROCEDURE

The procedure for copying the files into the Solar Post internal system is as follows:-

1. Activate a message by moving in front of the PIR sensor. Using a dark coloured eg (black insulation tape) cover the PIR hole. This prevents the PIR sensor from activating.
2. Wait a further 10 seconds then fully insert the programmer head into the four clear speaker holes. (See diagram right)
3. Switch the programmer ON – the RED LED lights, wait until the RED LED flashes.
4. Peel back the tape then activate the PIR sensor by moving. The AMBER LED lights and remains lit until the memory is fully erased (approx 90 seconds).
5. The GREEN LED will then flash as the message data is transferred. This could take several minutes (20 seconds per MByte of data).
6. When all messages are programmed, all 3 LEDs go off, and the solar post will begin to play the volume level routine. Turn the programmer off then select your volume by removing the programmer at the desired level.
7. Test the solar post content by activating the PIR. Switch OFF the programmer off and store in a safe place for future use.

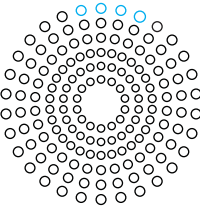

Download our audio encoding software and guide:

http://www.blackboxav.co.uk/product-downloads/audio_encoding_guide.zip