

Operation of the Solar Post Button could not be simpler...

1. **Push** button 1 to hear audio track 1.
2. **Push** button 2 to hear audio track 2.

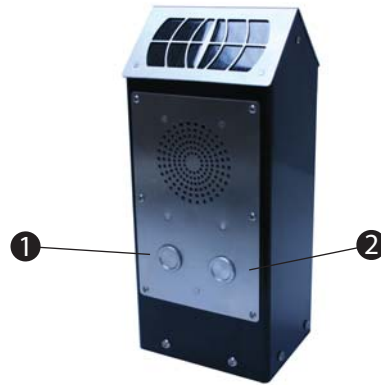

ADJUSTING THE VOLUME

There are 4 preset volume levels for the Solar Post which can be selected via the programming port. Once selected, the volume setting is stored and this level will be used for all messages.

1. Ensure the Solar Post is not playing a message.
2. Fully insert the volume dongle or programmer head into the four clear speaker holes. (See diagram right)
Note – If you are using the programming head please ensure that the SD card is removed and power on.
3. Press a button for 3 seconds. The unit will play the volume setting message “Volume level 1, volume level 2, volume level 3, volume level 4”. The solar post repeats this message again. The volume level changes for each message to match the volume setting i.e. 1-4.
4. When the desired volume level is heard you should remove the dongle (or programmer head) before the next volume message is played. This sets the volume to the last setting played.
5. The solar post will beep momentarily to indicate that the volume level is stored and the unit is ready for use at the new setting.
6. Test the volume setting by pressing the button. Store the dongle or programmer safely for future use.

The Solar Post is capable of giving playback statistics:

- “Message played” - Resettable Statistic
- “Message play total” - Non Resettable

Follow the steps below to track these statistics;

1. Ensure the Solar Post is not playing a message.
2. Fully insert the volume dongle or programmer head into the four clear speaker holes. (See diagram right)
Note – If you are using the programming head please ensure that the SD card is removed and power on.
3. Press a button for 3 seconds. A red LED will show and the unit will play the volume setting message “Volume level 1, volume level 2, volume level 3, volume level 4”. This will then repeat a second time. Leave the volume dongle in.
4. The solar post will next play the playback statistics “message played” - to 6 zeros (twice) followed by “message play total” - to 6 zeros (twice). You need to remove the volume dongle at this stage unless you want to erase the message played statistics back to zero (this will only erase the message played and not the message play total).
5. To erase the playback data simply leave the volume dongle in the unit. You will hear 5 pairs of warning beeps before the information is reset.

The system will then loop “message played” followed by “message play total” endlessly, until you remove the volume dongle.
6. Remove the dongle from the unit. The volume setting will remain as set before but it is advisable to test the unit by pressing a button. Store the dongle or programmer safely for future use.

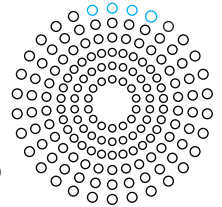

SPECIFICATIONS

Messages

Message storage medium:	32MByte Flash Memory (on board)
Maximum number of messages:	2 files on card no more, no less.
Message encoding format:	Windows PCM (*.wav)
Message sampling type/rate:	16 bit mono / 22.05, 16.0, 11.025 KHz
Maximum total message length:	>24 minutes @ 11.025KHz
Memory Erase Time:	Approx 90 seconds
Programming Transfer Rate:	Approx 20seconds/MByte of message
Message selection via 2 buttons	
Please note: Programmers are not provided as standard with the solar post but are available at additional cost.	

Message Output

Playback sample type/rate:	12 bit mono / 22.05, 16.0, 11.025 KHz
Audio output:	0.75W into 8ohm speaker
Freq. range:	75Hz-20kHz

Power

4 built in Solar Panels charging 3 1.2V long life batteries at up to 100mA per hour.
3 x 2200mAh long life batteries.

Weight

Tall metal boxed 10KG
Tall oak 60kg

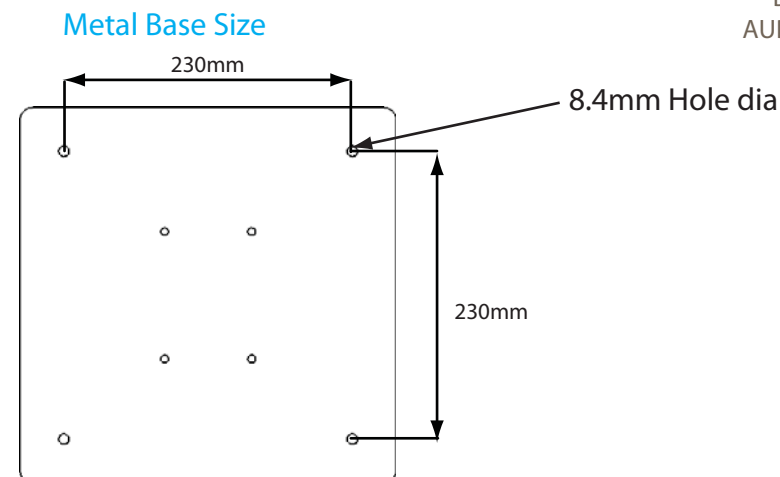

How can you tell if your solar post is charging?

At the end of each message a red light located in the lower half of the grill will blink if the electronics are receiving charge.

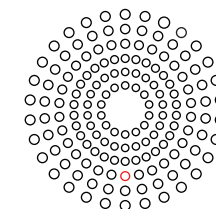

Wall Mounting a Short Solar Post Button

1. Remove the 6 security screws from the stainless steel front plate and take out the electronics. Disconnect the electronics by pulling the black connector apart - this disconnects the solar panels.
2. Offer the black solar post case up to the wall where it is to be mounted and mark through the rear plate the four fixing holes.
3. Screw through the solar post rear plate attaching the solar post to the wall.
4. Reconnect the solar panels by clicking the black connector back together and screwing the solar post front plate back onto the case via the 6 security screws.

PROGRAMMING GENERAL INFO

The audio files are initially created on a computer. The files are copied to an SD card which is inserted in the hand-held programmer.

The programmer is then connected to the Solar Post and the file transfer process is started. The files are copied to the audio board and stored on the internal on board memory. After completing the transfer, the programmer is removed from the U-Turn and it is ready for use.

The audio file format for the system is Windows PCM file format (i.e. .wav files). The audio must be mono, 16 bit samples at 22.05 KHz sampling (16KHz or 11KHz sampling rates are also allowed). The audio should be normalized to 100% amplitude to ensure best quality when played back on the system.

We recommend converting your audio using our encoding guide and software:

http://www.blackboxav.co.uk/product-downloads/audio_encoding_guide.zip

The SD card MUST be formatted as FAT (not FAT32) with a blank volume name before copying the 'wav' files. This is done by right clicking the SD drive icon from 'My Computer' and selecting FORMAT.

The audio files on the PC hard disc MUST be named '01' and '02'. There can be a maximum of 2 audio files on the SD card.

You then copy each file in turn from the PC hard disc to the SD card root directory. Do not put any other files on the SD card.

Note that copying files to the SD card can take longer than the computer indicates i.e. the computer will show that copying is finished but there is still data to be transferred to the card. Please ensure all files have been copied to the SD card before it is removed. The best way to confirm this is to 'click' the 'Unplug or Eject Hardware' button in the 'System Tray' icons (bottom right of screen), and then select 'STOP xxxxxxxx' where xxxxxxxx represents the SD card drive. If all the data has been transferred then a message will indicate that you can remove the card, if not then wait a while and try stopping the device again. Remember that you should not have 'My Computer' or 'Windows Explorer' accessing the SD card at this time otherwise the computer will assume the card is in use and will not allow it to be removed.

The programmed card should then be inserted label side up.

PROGRAMMING PROCEDURE

The procedure for copying the files into the Solar Post internal system is as follows:-

Note; Before programming please ensure there has been no message playback for 15 seconds.

1. Ensure the SD card is inserted in the programmer and the programmer is switched OFF before beginning the programming process.
2. Look carefully at the speaker holes; you should notice 4 holes which are clear from the protective mesh. They are located in the outer ring, top right of the speaker hole array. (See diagram) Align the programmer head pins to the 4 outer holes of the speaker grill. Do not force the pins in to the holes.
3. Switch the programmer ON – the RED LED lights, wait until the RED LED flashes.
4. Press and hold any button until the AMBER LED lights and remains lit until the memory is fully erased (approx 90 seconds).
5. The GREEN LED will then flash as the message data is transferred. This could take several minutes (20 seconds per MByte of data).
6. When all messages are programmed, all 3 LEDs go off, and the solar post will begin to play the volume level routine. Select your volume by removing the programmer at the desired level.
7. Test the solar post content by pressing a button. Switch OFF the programmer and store in a safe place for future use.

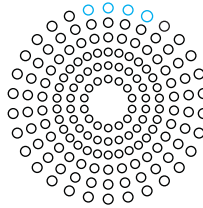

MAINTENANCE

Battery

Each audio solar post uses 3 rechargeable AA 2900mAh nickel metal hydride batteries which need to be replaced approximately every 2 years.

Tools

T20H Torque Bit (security bit)

Cross Head Screwdriver

5.5mm Spanner

Procedure

1. Unscrew the 6 security screws from the front panel using the T20H pin torque screwdriver.
2. Pull the front panel forward **slowly**; do not exceed the solar cable.
3. Unplug the solar cable and remove the solar electronics from the post
4. You will need to open the electronics box by removing the 6 cross head screws and nuts.
5. Locate the black battery box inside and remove the small cross head screw from the back.
6. Slide the box cover open.
7. Replace the old batteries with the new. Its a good idea to push a button to ensure the batteries are connected and the audio player is working.
8. Replace cover and screw to secure the battery box.
9. Replace the 6 cross head screws and nuts to seal the electronics.
10. Re-connect the solar panel cable.
11. Replace the 6 screws to secure the front panel in place.
12. Test by pressing a button. We advise checking after replacing batteries that charge is being received by the electronics (you will need a sunny day for this)

At the end of each message a red light located in the lower half of the grill will blink if the electronics are receiving charge.

Cleaning

We advise cleaning the solar posts and panels annually. Mild soap and water is best for general cleaning. Rinse with clean water after washing. All surfaces should be cleaned using a soft cloth or sponge, using nothing harsher than natural bristle brushes; do not scour painted surfaces.

SOLAR POST BUTTON FRONT PLATE

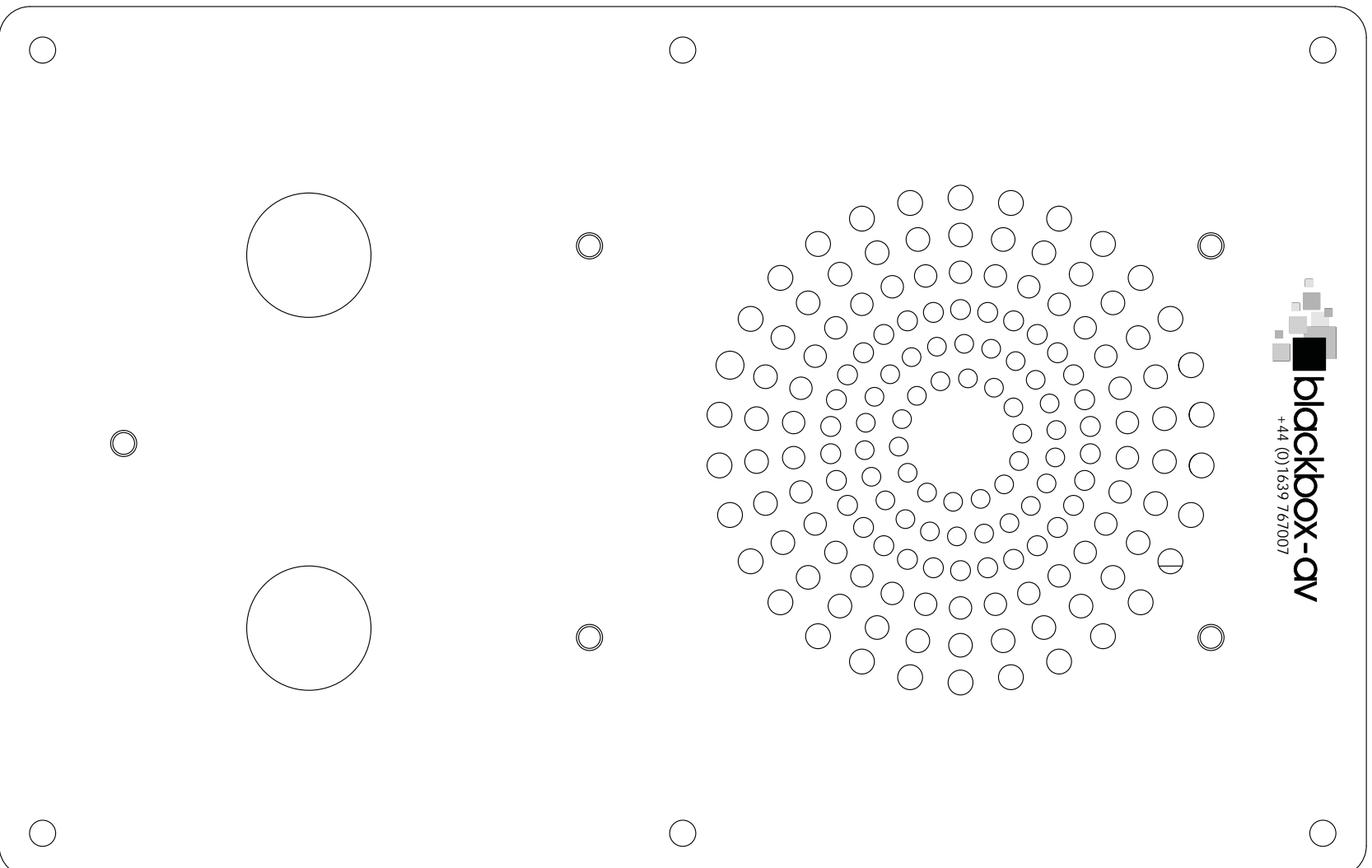

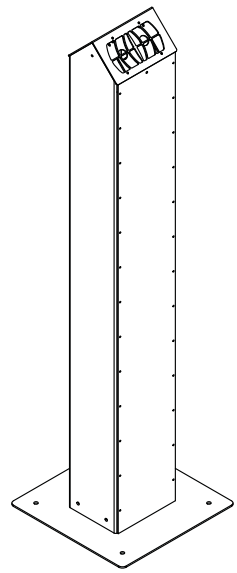
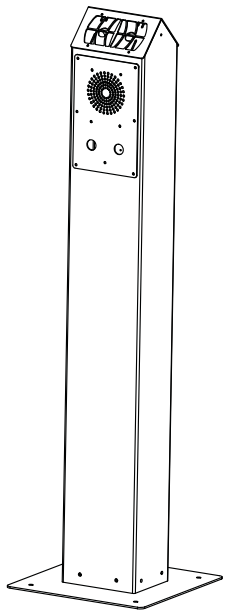
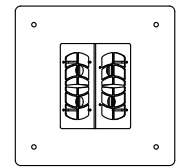
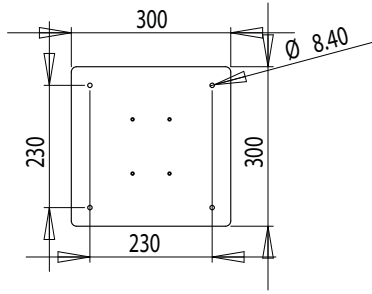
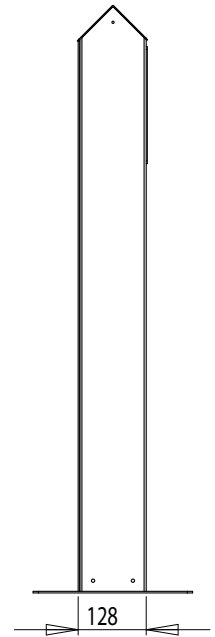
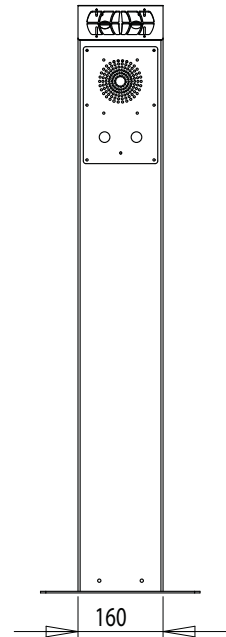
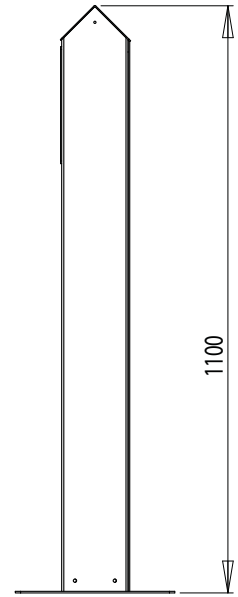
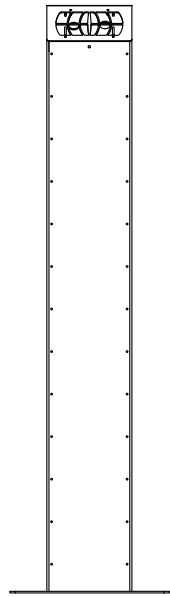

TALL METAL

UNLESS OTHERWISE SPECIFIED: DIMENSIONS ARE IN MILLIMETERS		FINISH: Powder coated Black		DERUR AND BREAK SHARP EDGES		DO NOT SCALE DRAWING		Drawing Number	
SURFACE FINISH:						blackbox-av.co.uk		01639 767 007	
TOLERANCES:						TITLE:			
LINEAR:						Solar Post Button Tall Metal			
ANGULAR:									
DRAWN	NAME	SIGNATURE	DATE						
CHKD	David Knight	DK	28/09/10						
APPV'D	Chris Crayford	CDC	28/09/10						
MFG									
QA									
				MATERIAL:		DWG NO.			
				Aluminium 2mm		SPB-Tall-metal-4/10/11-v1		A3	
				WEIGHT:		SCALE:1:10		V1	
						SHEET 1 OF 1			

TALL OAK

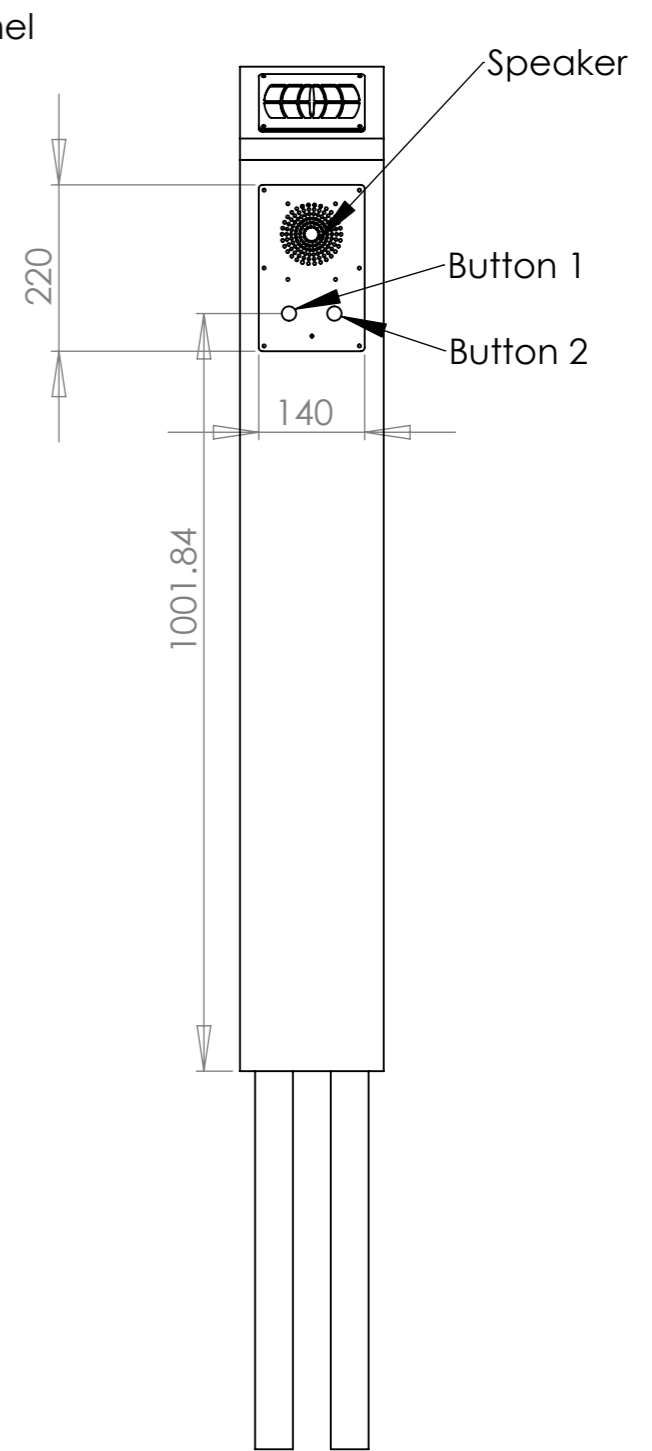
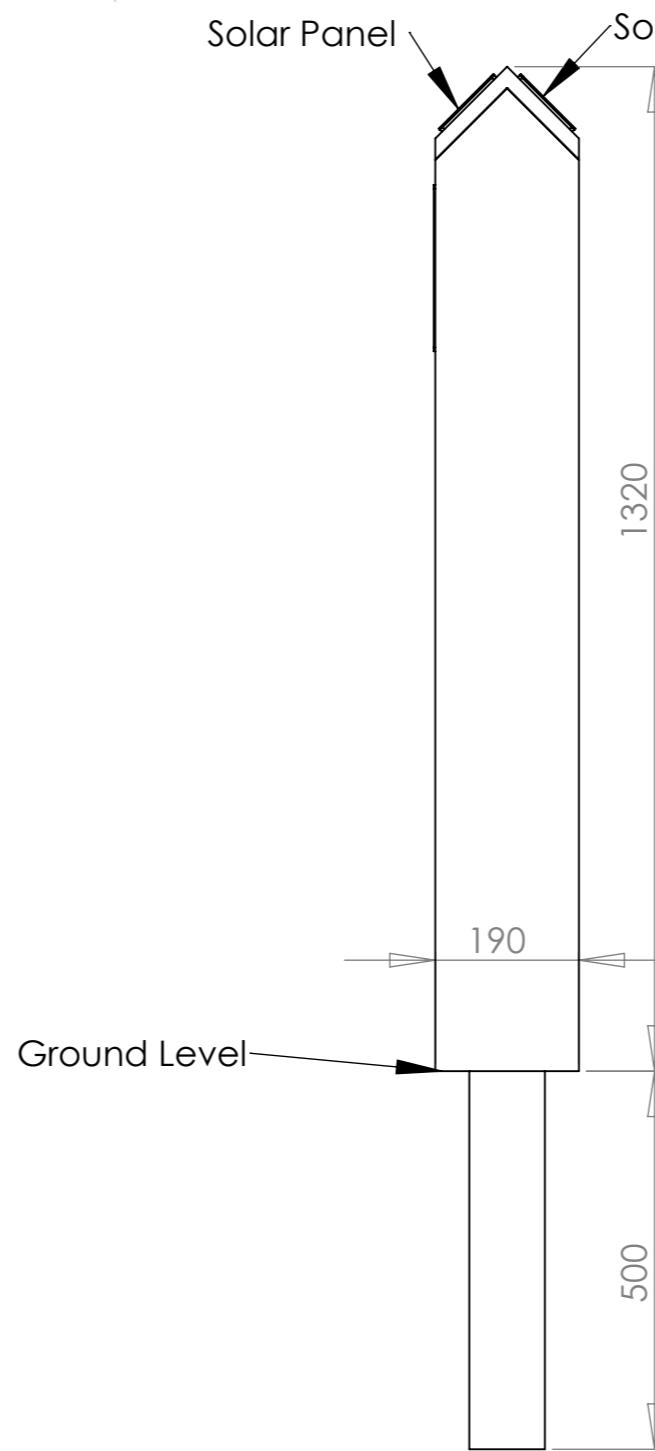
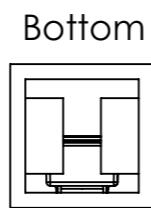
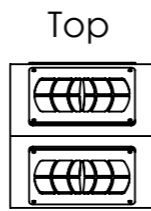
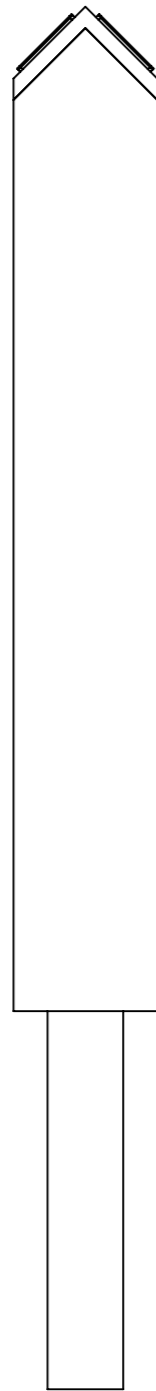
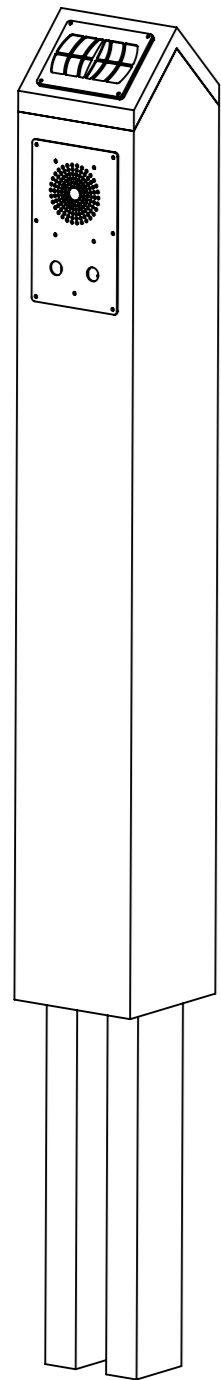

UNLESS OTHERWISE SPECIFIED:
DIMENSIONS ARE IN MILLIMETERS
SURFACE FINISH:
TOLERANCES:
LINEAR:
ANGULAR:

FINISH:

Stained

DEBUR AND
BREAK SHARP
EDGES

DO NOT SCALE DRAWING

Drawing Number

blackbox-av.co.uk 01639 767 007

	NAME	SIGNATURE	DATE
DRAWN	David Knight	DK	1/1/13
CHK'D	Chris Crayford	CDC	1/1/13
APPV'D			
MFG			
Q.A			

MATERIAL:
Oak

TITLE:
Solar Post Button Tall Oak

DWG NO. SPB-Assem-01-01-13

A3
V1

WEIGHT:

SCALE:1:10

SHEET 1 OF 1